



FRANK Puddle Flanges

The Original





FRANK puddle flanges

The original

In the early 1980s, FRANK developed and patented the FRANK puddle flange, a sealing system in use today in millions of buildings and structures all over the world. The original.

The FRANK puddle flanges, suitable for all standard pipes in steel, plastic, stoneware, concrete and cast iron from d 20 to d 3200, have been specifically designed for the pressure-tight installation of pipelines in concrete walls, foundation plates and manholes. FRANK puddle flanges are pressure-tight up to 10 bar, preventing the ingress of pressurised water, diffusing

media such as gases (e.g. radon) and hydrocarbons (e.g. oil, petrol). The FRANK puddle flange is an extremely flexible product available in a range of versions. A perfect solution for any application! Easy to install. Cost-effective alternative to conventional sealing systems.



Installation

Quick and easy

Installing a FRANK puddle flange takes only a few minutes.

The puddle flange is mounted by hand on the pipe and secured with the supplied clamping bands as described in the installation instructions. A screwdriver can be used to install the clamping band on pipes of up to 500 mm in diameter.



For larger pipes, use a clamping tool.

FRANK puddle flanges are not designed to serve as anchor points for pipes. For strong PE or PP wall ducts, FRANK offers special sections with single-side or double-side flanges.



With Easy-Lock function

Our puddle flange installation kits (d 20 to d 500) come with an Easy-Lock function. With this technique, the puddle flange can be clamped on the pipe many times faster. The use of a cordless screwdriver is possible (tightening torque approx. 5 Nm).



Video: Puddle flange assembly
Instructions with
Easy-Lock-function



Video: Puddle flange assembly
Instructions with clamping tool



Protection against radioactive gas

Radon-resistant, gas-tight puddle flanges from FRANK

Radon is a naturally occurring radioactive gas and comes from the natural radioactive decay of uranium and thorium. These metals occur naturally in bedrock and the release of radon therefore depends on the local geology. You cannot see, smell or taste radon.

The gas diffuses through the soil and is released into the atmosphere where it is found in very small concentrations. Out-

side of buildings, radon is therefore not a problem. The gas can however enter buildings, for example through cracks and joints, defective foundation plates in the basement or the ground floor, or along cable and pipe ducts. In this case, the radon concentration builds up gradually, often exceeding the limit values recommended by the German Federal Office for Radiation Protection. Tight foundations,

solid constructions and special ventilation measures help keep the radon concentration in buildings low.

When installing pipes and cable ducts through building walls, we therefore recommend using the special orange FRANK puddle flanges which are tested for radon-tightness.

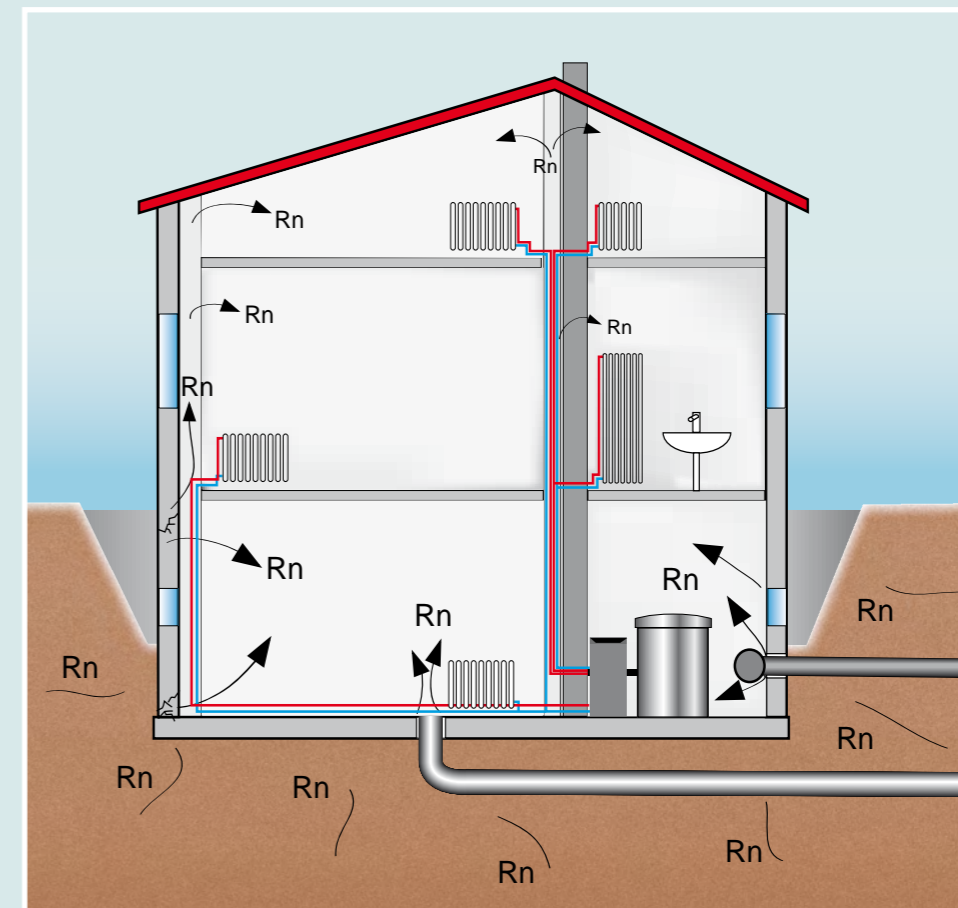

Radon-tight FRANK puddles flanges (orange)

Pressure-tight up to 10 bar!

Safe and versatile

Externally tested and certified

The independent material testing institute MFPA Leipzig GmbH checked the FRANK puddle flange for its sealing effect and, with professional installation with at least 50 mm coverage in waterproof concrete, confirmed - depending on diameter and design - a sealing effect of 5 bar to 10 bar.

Characteristics

FRANK puddle flanges made in EPDM

EPDM is chemically resistant to a wide range of acids and bases. It also offers outstanding weather and ozone resistance. For applications in connection with oil and petrol, FRANK puddle flanges made in NBR are the preferred option.

Density	1,030 kg /m ³
Shore hardness	40° Sh ± 3
Tensile strength	10 N/mm ²
Elongation at fracture	750 %
Tear propagation strength	3.9 N/mm ²
Temperature resistance	-50...+140 °C
Deformation under pressure (72 h, 70 °C)	32 %

Choosing the right pipe

FRANK products for all applications

The FRANK puddle flange can be installed on any type of pipe material, from plastic, steel and stoneware to concrete, cast iron, fibre cement or GFRP. The FRANK puddle flanges are available for all conventional outside diameters.



MFPA Leipzig GmbH
Prof.-Überwachungs- und Zertifizierungsstelle für
Baustoffe, Bauprodukte und Bausysteme
Geschäftsbereich V - Tiefbau
Prof. Dr.-Ing. Olaf Seile
Arbeitsgruppe 5.1 - Bauwerksabdichtung

Untersuchungsbericht UB 5.1/13-445

vom 12. Januar 2014
1. Ausfertigung

Gegenstand: Frank Mauerkragen d 110 -
Prüfung der Dichtigkeit im Einbauzustand

Auftraggeber: Frank GmbH
Starkenburgerstraße 1
64546 Mörfelden-Walldorf

Probeneingang: 05.09.2013

Probeneingangsnummer: 614



Prüfzeitraum: September 2013 – Januar 2014

Bearbeiter: Dipl.-Ing. Jüling

Dieses Dokument besteht aus 3 Seiten und einer Anlage.

Dieses Dokument darf nur ungekürzt vervielfältigt werden. Eine Veröffentlichung – auch auszugsweise – bedarf der vorherigen schriftlichen Zustimmung der MFPA Leipzig GmbH. Als rechtsverbindliche Form gilt die deutsche Schriftform mit Originalunterschriften und Originalstempel des/der Zeichnungsberechtigten.

Es gelten die Allgemeinen Geschäftsbedingungen (AGB) der MFPA Leipzig GmbH.

  	<small>Durch die DAKKS GmbH nach DIN EN ISO/IEC 17025 akkreditiertes Prüflabor. Die Akkreditierung gilt für die in der Urkunde aufgeführten Prüfverfahren. Dieses Dokument ist ein Gemeinschaftsprodukt. Die Urkunde kann unter www.mfpa-leipzig.de eingesehen werden.</small>	<small>Gesellschaft für Materialprüfung und Prüfungen für die Baustoffe Leipzig mbH (MFPA Leipzig GmbH) Sitz: Hans-Winkel-Str. 21 - 04219 Leipzig/Dennmark Geschäftsführer: Prof. Dr.-Ing. Frank Dahn Hans-Winkel-Str. 21 04219 Leipzig Tel.: +49 (0) 341 - 6582-0 Fax: +49 (0) 341 - 6582-135</small>
---	---	--

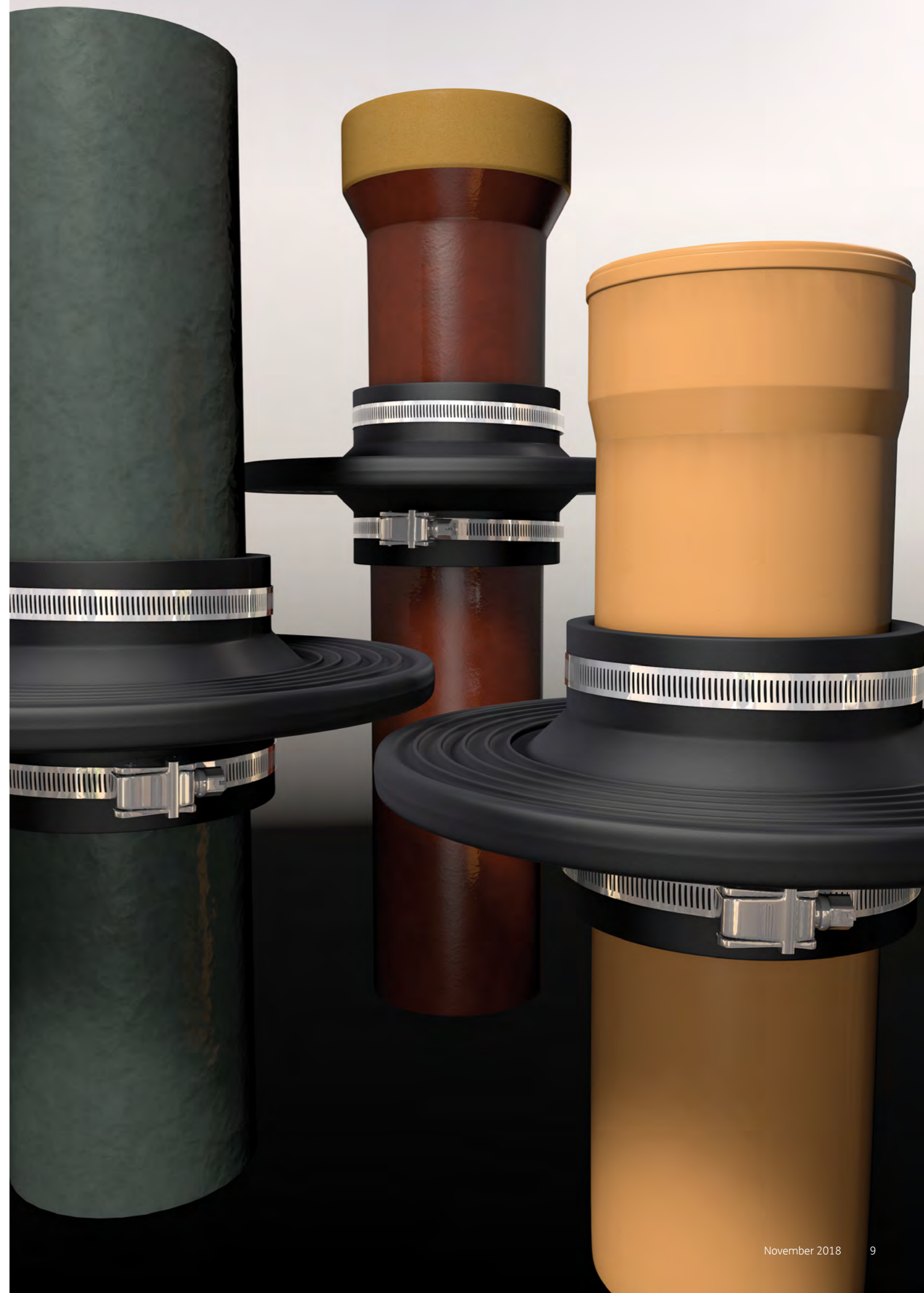

Successfully installed 1.5 million times throughout the world

Examples of applications

- Swimming pool drain pipes in walls and foundation plates

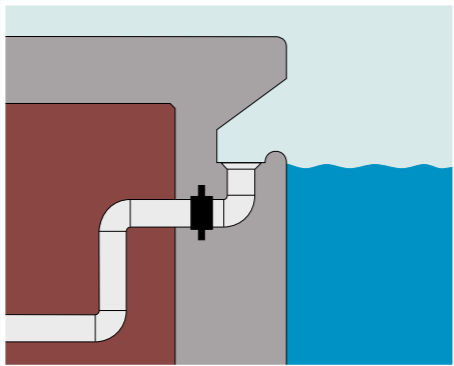

- Pre-fabricated wall lead-through with flange connectors on both sides for easy installation into formwork

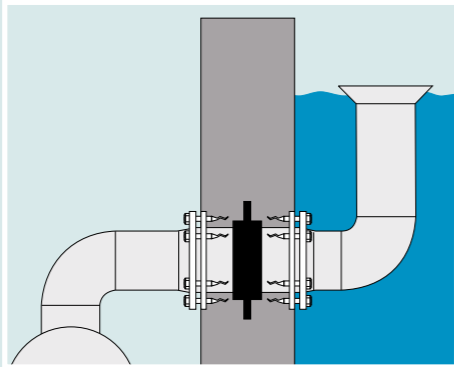

- Floor drain in industrial building

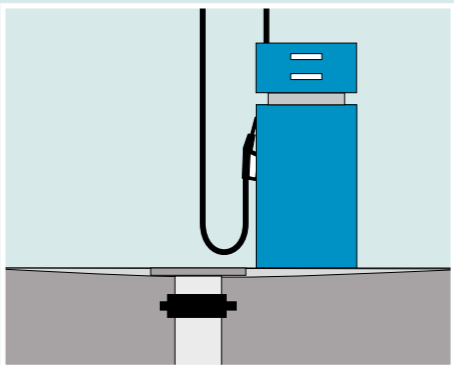
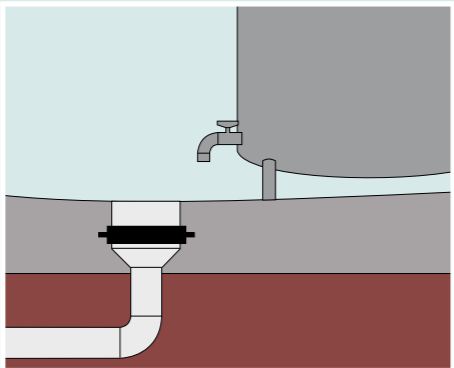

- FRANK puddle flange made in oil- and petrol-resistant NBR at a filling station

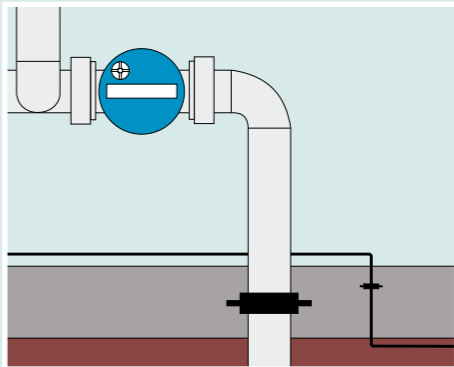

- House lead-ins for water supply and discharge pipes as well as for lightning protection earthing strips and ground wire.

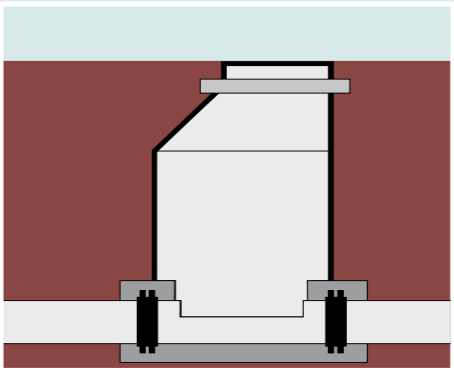

- Integration of pipes of any outside diameter into concrete manholes

Product range

Puddle flange installation kit (d 20 to d 500) tight up to 100 m water head

Puddle flange installation kit consisting of:

- 1x puddle flange
- 2x stainless steel clamping bands (matching flange dimensions)

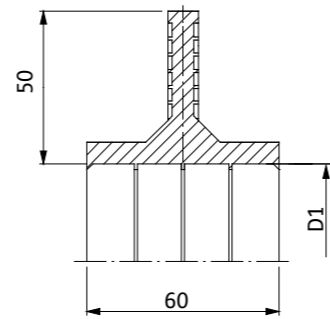

d _{pipe} [mm]	Ø range of installation kit [mm]	D ₁ [mm]	Weight [kg/unit]	Installation kit product no. 90 954 ...
20	18-24	16	0,20	0020 01
25	23-29	21	0,25	0025 01
32	31-37	29	0,16	0032 01
40	40-46	38	0,20	0040 01
50	50-56	48	0,24	0050 01
63	62-69	60	0,26	0063 01
75	73-82	71	0,30	0075 01
90	86-97	84	0,34	0090 01
100	98-109	95	0,36	0100 01
110 ¹⁾	108-121	105	0,40	0110 01
125 ¹⁾	123-136	120	0,46	0125 01
140	136-155	132	0,50	0145 01
160 ¹⁾	158-177	154	0,56	0160 01
180	177-197	173	0,60	0180 01
200 ¹⁾	199-224	195	0,70	0200 01
225	220-249	215	0,78	0225 01
250	250-279	245	0,84	0250 01
280	280-314	275	0,86	0280 01
315	315-354	310	1,06	0315 01

From d 355 the big puddle flange will be delivered with 3x stainless steel clamping bands

355	355-399	310	1,32	0355 00
400	400-449	353	1,66	0400 00
450	450-499	400	1,80	0450 00
500	500-559	448	2,15	0500 00

Other dimensions available on request.
All dimensions also available in NBR.
1) NBR version available in stock.

Puddle flange (from d 560) tight up to 80 m water head

Puddle flange and clamping band as individual components

- Puddle flange (product no. 90 954 ...)
- Galvanized clamping band, 30 m roll (product no. 97 955 0031 00)
- Stainless steel fastener for clamping band (product no. 95 957 0000 00), 3 steel fasteners per puddle flange
- Clamping tool available for rent or purchase (product no. 95959 0000 00)

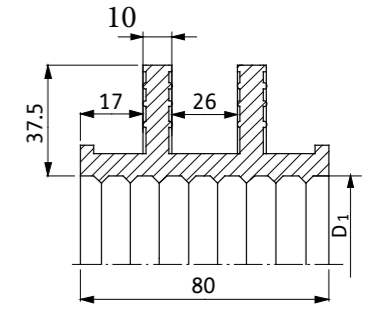

d _{pipe} [mm]	Ø range [mm]	D ₁ [mm]	Clamping band length per puddle flange L [m]	Weight [kg/unit]	Product no. 90 954 ...
560	560-629	505	12.3	2.30	0560 00
630	630-709	571	13.8	2.55	0630 00
710	710-799	648	16.2	2.64	0710 00
800	800-899	733	17.1	3.22	0800 00
900	900-999	828	18.0	3.60	0900 00
1000	1000-1150	923	19.8	3.88	1000 00
1200	1200-1350	1113	23.7	5.64	1200 00
1400	1400-1550	1303	28.0	6.44	1400 00
1600	1600-1750	1490	31.9	7.25	1600 00
1800	1800-1990	1680	38.0	8.20	1800 00

Other dimensions available on request.



Puddle flange from d 355 mm

Puddle flange from d 20 to d 315 mm

Product range

FRANK Puddle flange installation kit for lightning protection earthing strips and ground wire

Tight up to 60 m water head.

Puddle flange installation kit consisting of:

- 1x puddle flange
- 2x stainless steel clamping bands (matching flange dimensions)

[mm]	Product no. 90 954...
for round steel from d 8 to 10 mm	0010 01
for flat steel from 3 to 3,5 x 30 mm	0003 01



FRANK wall installation kit

The FRANK wall installation kit is designed for the installation of standard sewerage and HT pipes in concrete walls and floors. The wall installation kit is a pre-assembled unit for the flush integration into the shuttering for concrete walls. By shortening the centre section, the wall installation kit can be adjusted to match the wall thickness. For very thick walls, the kit can be extended with a standard sewerage/HT pipe section. The system is tight up to 100 m water head.

d ₁ [mm]	d ₂ [mm]	l _{e1} [cm]	Product no. 90 970 ...
110	216	21 - 30 cm	0110 00
160	268	26 - 33 cm	0160 00

Other dimensions available on request.
Other lengths available on request.

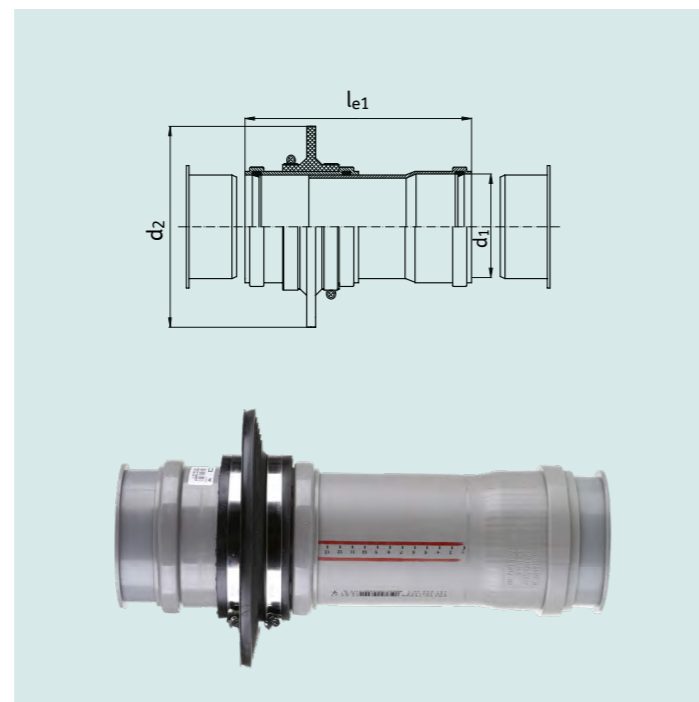

FRANK wall lead-through kit with flange connections

The FRANK wall lead-through kit is a tried and tested method for the safe and long-lasting installation of pipes through walls and floors. Made in PE or PP, they meet the requirements for swimming pools and industrial pipeline systems. The pre-assembled kit can be easily installed in the wall or foundation plate.

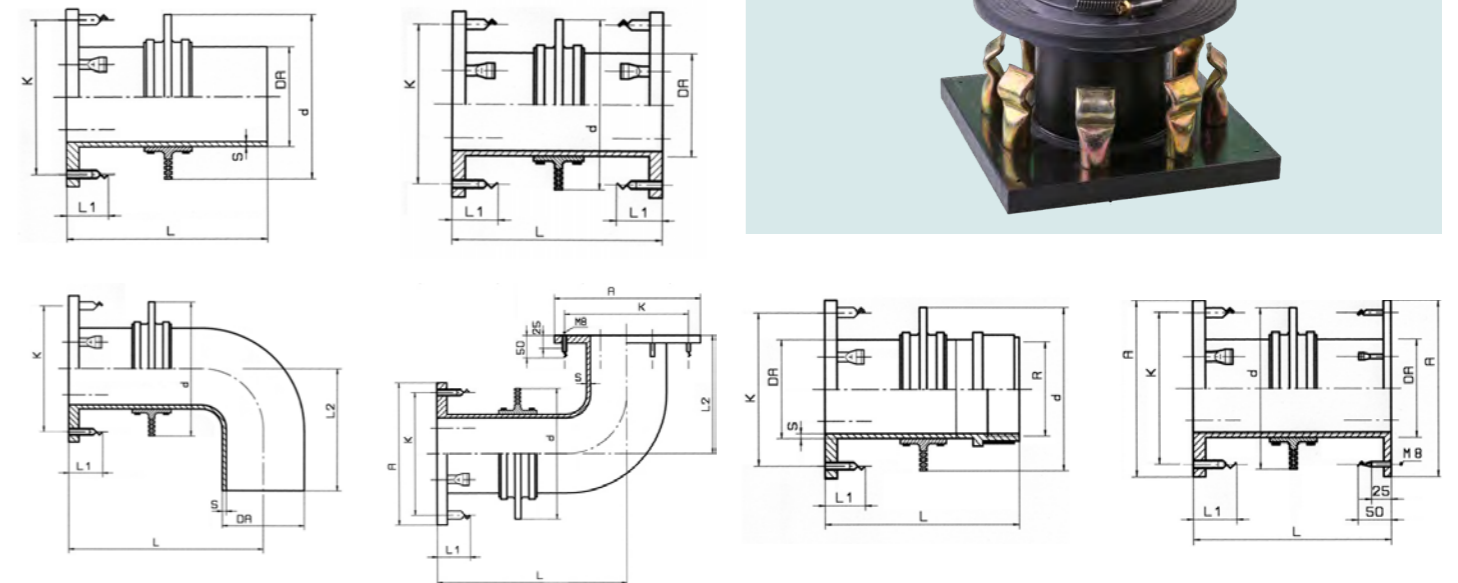

FRANK manhole connection socket SAM type 1

- Tight up to 100 m water head, depending on diameter
- For tight connections of PE pipes in concrete manholes
- With integrated electrofusion wire for the welding of SAM manhole connection socket to the PE pipe

d [mm]	DN [mm]	L [mm]	D ₂ [mm]	Tightness	Prod. no. 25 178
160	150	135	297	100 m water head	0160 17
225	200	135	372	100 m water head	0225 17
280	250	135	445	100 m water head	0280 17
355	300	135	515	80 m water head	0355 17
450	400	135	573	80 m water head	0450 17
560	500	135	699	80 m water head	0560 17

Other dimensions available on request.

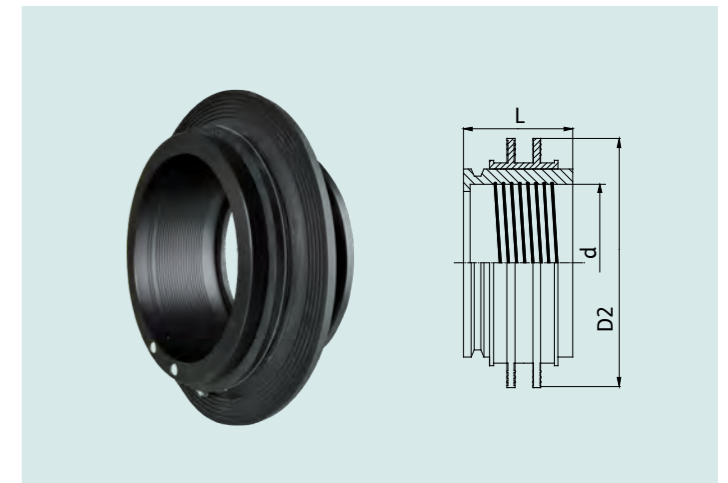

FRANK GmbH
Starkenburgerstrasse 1
64546 Mörfelden-Walldorf
Germany
T +49 6105 4085 - 0
F +49 6105 4085 - 249
info@frank-gmbh.de
www.frank-gmbh.de